



TL46-WL Contrast sensor

INSTRUCTION MANUAL

CONTROLS

OUT LED (yellow)

The yellow LED indicates the output status.

READY LED (green)

During functioning, the green LED permanently ON indicates a normal operating condition. Fast blinking indicates an output overload condition.

DELAY LED (orange)

The orange DELAY LED ON indicates the timing function activation on the digital output.

KEYLOCK LED (orange)

The orange KEYLOCK LED ON indicates the active keyboard status.

BARGRAPH

The switching threshold level is signalled on the bargraph.

SET PUSH-BUTTON (bianco)

The detection procedure is activated by pressing the SET push-button.

+ (red) and - (green) PUSH-BUTTONS

The threshold adjustment procedure is activated by pressing the + and - push-buttons.

See the "SETTING" paragraph for the correct adjustment phase indications.



INSTALLATION

The sensor can be positioned by means the two Ø3.5mm housing's holes using or threaded M5 holes with 6mm max. depth.

Warning: the use of excessively long screws can damage the product.

The connector can be oriented at five different positions, rotating the block. The position chosen is guaranteed by a mechanical blocking system.

The rotation can be carried-out even after sensor installation as the connector block is completely self-contained inside the housing.



The operating distance is measured starting from the lens front face.

The reading direction can be changed inverting the cap and lens.

Mark detection on a reflective surface is improved adjusting the beam direction to 5° ... 20° from surface axis.

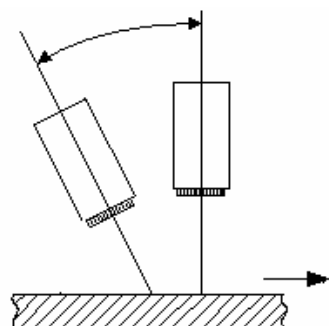

DIMENSIONS

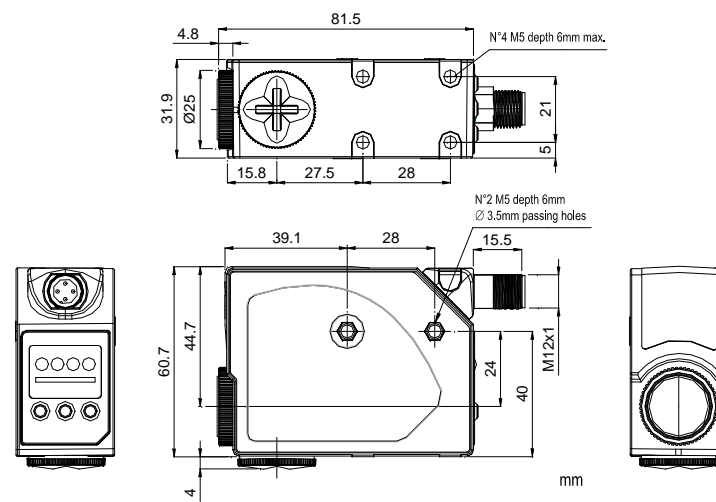

TECHNICAL DATA

Power supply:	10...30 Vdc (limit values)
Ripple:	2 Vpp max.
Current consumption (output current excluded):	85 mA max @ 24 Vdc with bargraph ON in threshold adjustment mode, 55 mA max @ 24 Vdc with bargraph OFF in normal functioning mode
Output:	1 selectable PNP/NPN output 30 Vdc max. (short-circuit protection) (default PNP configuration)
Output current:	100 mA max.
Output saturation voltage:	≤ 2 V
Response time:	25 μs
Switching frequency:	20 kHz
Analogue output:	1 ... 3 V ± 10% (90% white); 5.5 V max.
Analogue output impedance:	2.2 kΩ (short-circuit protection)
Delay	0 / 20ms selectable default configuration without delay
Dark/light selection:	Automatic
Indicators:	OUT LED (yellow) / READY LED (green) DELAY LED and KEYLOCK LED (orange) 5-segment bargraph
Operating temperature:	-10 ... 55 °C
Storage temperature:	-20 ... 70 °C
Electric shock protection:	double insulation
Operating distance:	9 mm
Depth of field:	± 3 mm
Minimum spot dimension:	1.5x5 mm
Emission type:	Blue (465 nm) / Green (520 nm) / Red (630 nm) with automatic selection
Ambient light rejection:	According to EN 60947-5-2
Vibrations:	0.5 mm amplitude, 10 ... 55 Hz frequency, for each axis (EN60068-2-6)
Shock resistance:	11 ms (30 G) 6 shock for each axis (EN60068-2-27)
Housing material:	Aluminium
Lens material:	Glass (*)
Mechanical protection:	IP67
Connections:	M12 5-pole connector
Weight:	170 g. max.

(*) It's available on request, PMMA plastic lens with 9mm focus.

CONNECTIONS

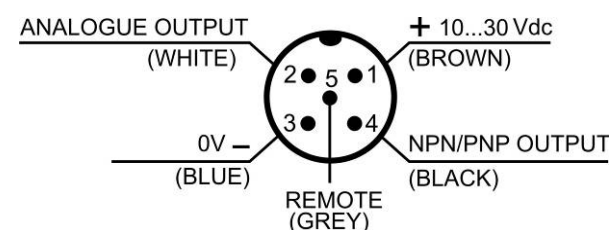

SETTING

KEYLOCK FUNCTION (PATENT-COVERED)

The KEYLOCK function deactivates the keyboard avoiding any accidental changes in sensor setting.

At sensor powering, the keyboard is blocked (KEYLOCK LED OFF).

The white (SET) push-button has to be pressed for 5 sec. until the KEYLOCK LED (orange) turns ON. The keyboard is blocked automatically if not used for 2 minutes.

The keyboard has to be unlocked to proceed with sensor setting.

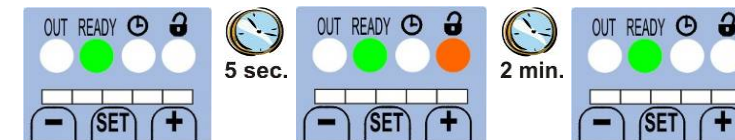

DETECTION (MARK-BACKGROUND)

Position mark in front of the sensor light spot and press white (SET) push-button until the READY LED (green) turns OFF.

The sensor detects the mark alternating the red, green and blue emissions; avoid mark movements during this phase.

Position the background in front of the sensor light spot and press white (SET) push-button again. The sensor detects the mark alternating the red, green and blue emissions. Avoid background movements during this phase.

The DARK/LIGHT operating mode is automatically selected by the sensor.

Dark mark - light background = dark mode; light mark - dark background = light mode.

If the READY LED is permanently ON, the detection is successful. If the LED blinks slowly, the detection has failed due to insufficient contrast. The sensor returns to the previous setting by pressing white (SET) push-button.

Repeat the procedure from the beginning.

SWITCHING THRESHOLD SETTING

The sensor switching threshold is adjusted by pressing the + or - push-buttons (respectively increasing or decreasing the value).

At the first pressure of the + or - push-buttons, the first three LEDs of the bargraph turn ON.



Increasing or decreasing the threshold, the right or left LEDs blink with a frequency proportional to the difference from the initial threshold value.

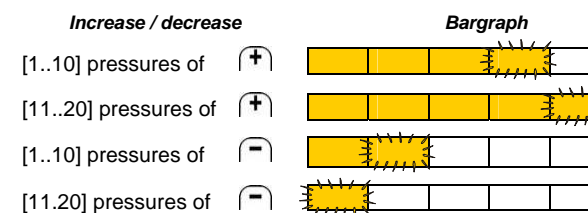

To save the new threshold value press white (SET) push-button or wait 30 sec. from last change (automatic save).

DELAY SETTING

The DELAY extends to 20ms the minimum duration of the active output allowing the slower interfacing systems to detect shorter pulses.

The active delay is signalled by the corresponding orange LED ON.

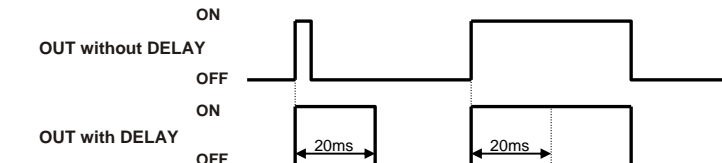

DELAY ACTIVATION

Press + and - contemporaneously for 2 sec. until the DELAY LED turns ON.



DELAY DEACTIVATION

Press + and - contemporaneously for 2 sec. until the DELAY LED turns OFF.



PNP/NPN OUTPUT SETTING

The digital output can be PNP or NPN configured.

To change output press red (+) push-button and green (-) push-button contemporaneously for 10 sec.

The setting is signalled by the status change of the DELAY LED.

If the delay is active after pressing the push-buttons for 2 seconds, the DELAY LED turns OFF, release the push-buttons only after LED re-powering (10 sec.).

If the delay is deactivated after pressing the push-buttons for 2 seconds, the DELAY LED turns ON, release the push-buttons only after LED turning off (10sec.).

The output setting is signalled by the KEYLOCK LED. Releasing the push-buttons, the KEYLOCK LED blinks once if the PNP output is set, blinks twice if the NPN output is set.

	2 sec. pressure of (+) and (-)	10 sec. pressure of (+) and (-)	Release of push-buttons
Delay ON	[Green, Orange, Yellow]	[Green, Orange, Yellow]	[Green, Orange, Yellow]
Delay OFF	[Green, Orange, Yellow]	[Green, Orange, Yellow]	[Green, Orange, Yellow]

OUTPUT OVERLOAD

The digital output overload is signalled by the rapid blinking of the READY LED.

ACCESSORY FUNCTIONS

REMOTE INPUT

The REMOTE signals carries-out the acquisition functions without using the white (SET) push-button.

The REMOTE wire connected to +Vdc is equal to pressing the white (SET) push-button. Whereas, if the REMOTE wire is connected to GND or not connected it is equal to not pressing the white (SET) push-button.

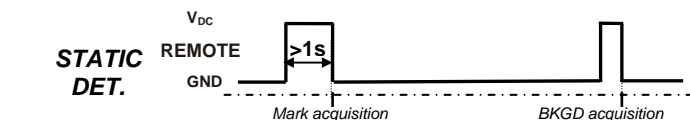

ANALOGUE OUTPUT

The analogue output supplies a voltage proportional to the signal received by the sensor. The voltage supplied is 1 ÷ 5.5V. The maximum voltage is obtained with reflective objects; on 90% white the voltage is equal to 3V.

	EX-II-3DG IP67 T6	
	Temperature class:	T6 (<85°C)
	Max. Power consumption:	2400 mW at 30 Vdc
	Max. Internal capacitance:	450 pF
	Internal inductance:	negligible

DECLARATION OF CONFORMITY

IDECC and DATASENSOR jointly declare under their sole responsibility that these products conform to the 2004/108/CE, 2006/95/CE Directives, and successive amendments.

IDECC and DATASENSOR reserve the right to make modifications and improvements without prior notification.